

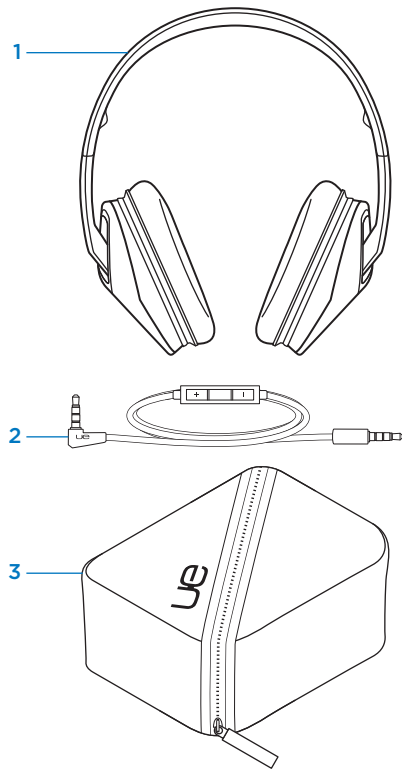

Setup Guide
Ultimate Ears™ 6000





Package contents

1. Headphones
2. Detachable audio cable with in-line remote
3. Travel case
4. Sharing splitter
5. 2 AAA alkaline batteries (pre-installed)
6. Documentation

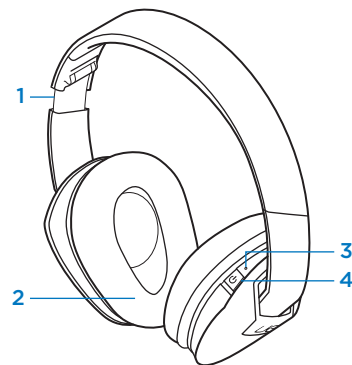
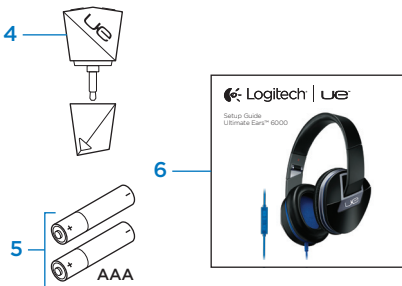

Know your product

1. Adjustable headband
2. Memory foam cushions
3. Battery LED
4. On/Off slider
5. Volume up
6. Media/calling controls
 - One click: Play/pause (audio)
Call answer/hang up (phone)
 - Double click: Next track (audio)
 - Triple click: Previous track (audio)
 - One click, then click and hold: Fast forward (audio)
 - Two clicks, then click and hold: Rewind (audio)
 - Click and hold: Activate/deactivate voice dial¹
7. Volume down
8. Microphone
9. Battery door release (Press button to open battery door.)
10. Battery compartment
11. 3.5 mm input

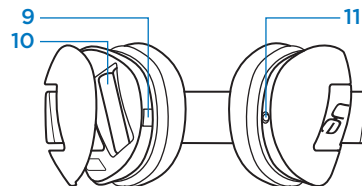
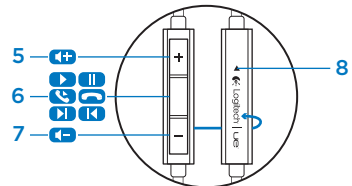

¹ Function varies by phone. Activates Siri[®] on iPhone[®] 4S.

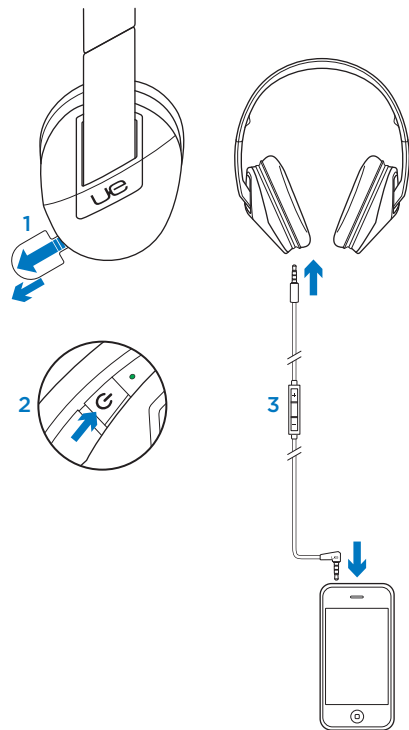

Set up your product

1. Pull the tab to activate batteries.
2. Move the slider to "On." The Battery LED turns green to indicate Active Noise Cancellation mode.
3. Connect the headphone to begin listening to music.

Product features

Answering a call

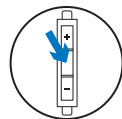

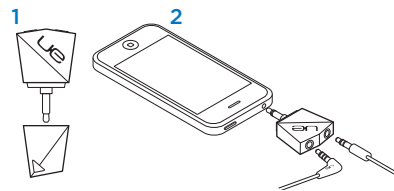

- On your phone, the music fades and a ring tone sounds.
- You can pick the call up on your phone or press the center button.
- To hang up, press the center button.

Sharing your music



1. Remove the cap.
2. Plug in the sharing splitter and connect. Listen to music together.

Active Noise Cancellation Battery LED

- No light: headphone off
-  Green: Power on; batteries good
-  Red: Low power; change the batteries

If the power runs out, Active Noise Cancellation ends. The headphones continue to play music. Replace batteries for optimal performance

Storage

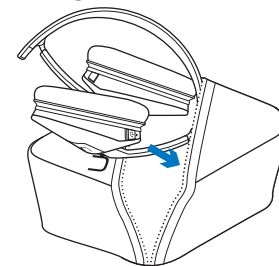

The headphone folds easily for storage.

Visit Product Central

There's more information and support online for your product. Take a moment to visit Product Central to learn more about your new Ultimate Ears headphone.

Browse online articles for setup help, usage tips, or information about additional features.

Connect with other users in our Community Forums to get advice, ask questions, and share solutions.

At Product Central, you'll find a wide selection of content:

- Tutorials
- Troubleshooting
- Support community
- Software downloads
- Online documentation
- Warranty information
- Spare parts (when available)

Go to www.logitech.com/support/ue6000

Troubleshooting

No sound or faint sound

- Check the cable connection. Make sure the straight connector is connected to the headphone and the angled connector is connected to your device.
- Try increasing the volume for the headphone and your media application.
- Restart your media application.
- If the Battery LED is red, replace the 2 AAA alkaline batteries.

Headphones not working with a computer

- Specify audio settings for your operating system:

Windows® (Control Panel)

- Voice playback and recording: Computer's soundcard
- Sound playback: Computer's speakers

Mac® OS X (Preferences)

- Sound input: Internal microphone
- Sound output: Internal speakers

Refer to your operating system documentation. For more information, go to www.logitech.com/support/ue6000.

What do you think?

Please take a minute to tell us.
Thank you for purchasing our product.

www.logitech.com/ithink

www.logitech.com/support/ue6000



United States +1 646-454-3200



POWER TO THE MUSIC

www.logitech.com

© 2012 Logitech. All rights reserved. Logitech, the Logitech logo, and other Logitech marks are owned by Logitech and may be registered. Apple, Mac, and the Mac logo are trademarks of Apple Inc., registered in the U.S. and other countries. Microsoft, Windows, and the Windows logo are trademarks of the Microsoft group of companies. All other trademarks are the property of their respective owners. Logitech assumes no responsibility for any errors that may appear in this manual. Information contained herein is subject to change without notice.

620-004307.002